

Instructions



**TDS7000 Series Rackmount (Option 1R)
for Digital Phosphor Oscilloscopes**

**TLA 600 Series Rackmount (Option 1R)
for Logic Analyzers**

**OTS9000 Series Rackmount (Option 1R)
Optical Test Systems**

071-0716-02

Warning

The servicing instructions are for use by qualified personnel only. To avoid personal injury, do not perform any servicing unless you are qualified to do so. Refer to all safety summaries prior to performing service.

www.tektronix.com



071071602

Copyright © Tektronix, Inc. All rights reserved.

Tektronix products are covered by U.S. and foreign patents, issued and pending. Information in this publication supercedes that in all previously published material. Specifications and price change privileges reserved.

Tektronix, Inc., P.O. Box 500, Beaverton, OR 97077

TEKTRONIX and TEK are registered trademarks of Tektronix, Inc.

Kit Description

This introduction describes the installation of option 1R (rackmount kit) to your standard bench-top instrument.

The rackmount kit is a collection of parts that, once installed, configure the instrument for mounting into a standard 19-inch equipment rack.

Products

TDS7000 Series All Serial Numbers
TLA 600 Series All Serial Numbers
OTS9000 Series All Serial Numbers

Kit Parts List

Figure 3 on page 8	Quantity	Part number	Description
-----	1 ea	016-1790-XX	Rackmount Kit: TDS7000 & TLA 600 Series, consisting of the following:
-----	1 ea	071-0716-XX	Tech manual: Instructions, TDS7000 & TLA 600 Series
3-1	1 ea	411-2229-00	Rackmount panel set consisting of: left and right side; and lower cover trim
3-2	1 ea	351-0313-00	Guide rack, consisting of: left and right side
3-3	4 ea	NS	Screw, mach: 10-32, panhead, 0.5 in l, phillips
3-3	7 ea	NS	Nut, locking washer: 10-32 assem
3-3	14 ea	NS	Screw, mach: 10-32, Truss-head, 0.5 in l, phillips
3-3	4 ea	NS	Screw, mach: M6 x 20 ovl head, phillips
3-3	4 ea	NS	Screw, mach: M5 x 20 ovl head, phillips
3-3	4 ea	NS	Screw, mach: 10-32 x 0.75 ovl head, phillips
3-3	4 ea	NS	Screw, mach: 12-32 x 0.75 ovl head, phillips
3-3	5 ea	NS	Washer: flat, nylon
3-4	1 ea	351-0241-01	Slide, drawer, extenders: Sliders
3-4	1 ea	NS	Rack: Mounting screws, nut blocks
3-5	2 ea	386-7279-00	Plate: ABS, bracket spacer
3-6	2 ea	367-0525-00	Handle: bracket, al, gray

NS – Not Saleable

Warranted Characteristics

When the instrument is installed according to the instructions in this document, the rackmounted instrument meets all warranted requirements listed in the instrument specification except for those listed in *Environmental Requirements on page 5*. Instruments mounted using methods other than those described in these instructions may cause the instrument to not meet its warranted requirements.

See *Specification* in the user or service manual that applies to your instrument model for tables of the warranted characteristics.

Cooling air enters on the bottom and right sides as shown in Figure 1. You assume the responsibility to provide adequate cool air to meet the ambient temperature requirements listed in Table 1.

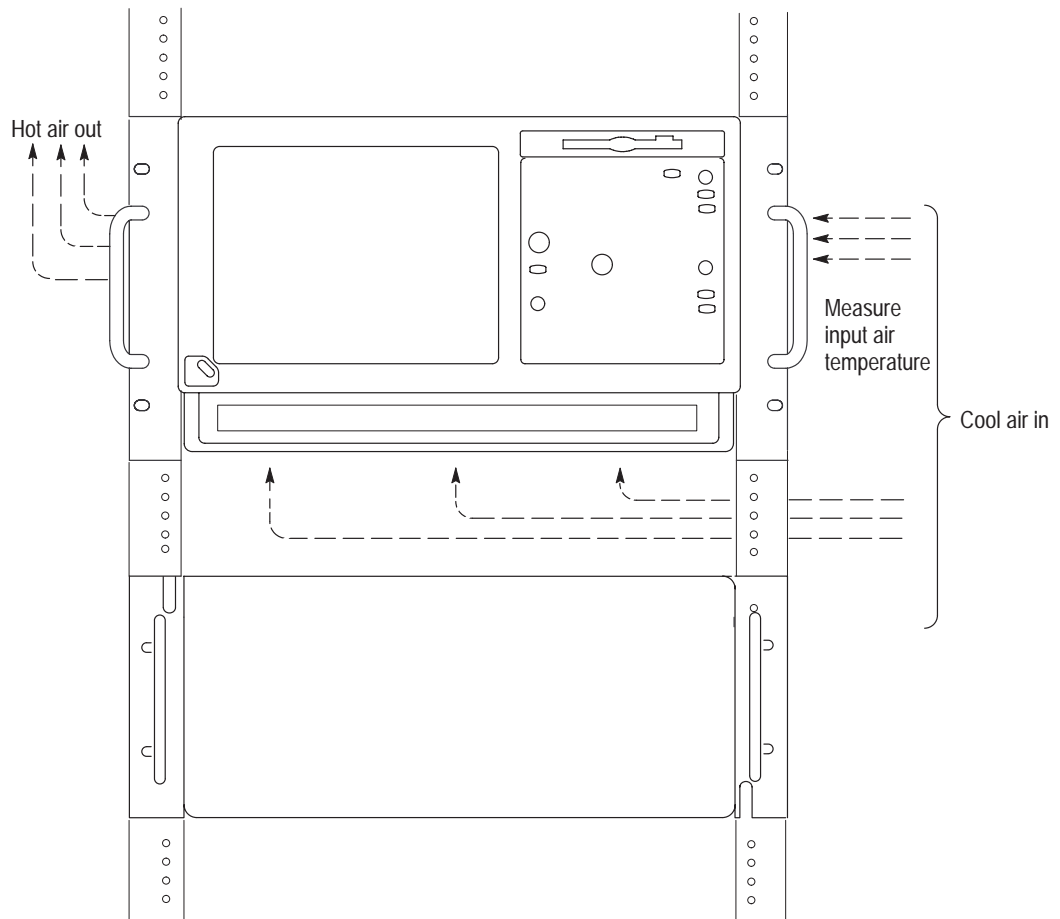

Figure 1: instrument cooling

Environmental Requirements

The following environmental characteristics supercede those listed in the user or service manual for your instrument. The following table does not apply to the OTS9000 Series instruments.

Table 1: Warranted characteristics

Characteristic	Description
Temperature, Inside Rack Cabinet	
Operating	+10° C to +45° C
Non-operating	-22° C to +60° C
Vibration	
Operating	0.24 g rms, from 5 to 500 Hz, 10 minutes each axis
Non-operating	2.22 g rms, from 5 to 500 Hz, 10 minutes each axis
Shock	
Operating and Non-operating	20 g, 11 ms, half sine, each axis, 3 drops each

Clearance Requirements

The rack in which the rack adapted instrument is mounted must provide the following clearance requirements:

- A minimum of 10.5 inches (266.7 mm) of vertical space.
- A minimum width of 17 5/8 inches (448 mm) between the left- and right-front rails in the rack.
- A minimum inside height depth of at least 20 inches (508 mm).



WARNING. Adhering to these clearance requirements mounts the rack-adapted instrument with sufficient clearance for air circulation and accommodation of the power cord and mounting hardware. Failure to provide these clearances can result in overheating and can cause the instrument to not operate properly and/or fail.

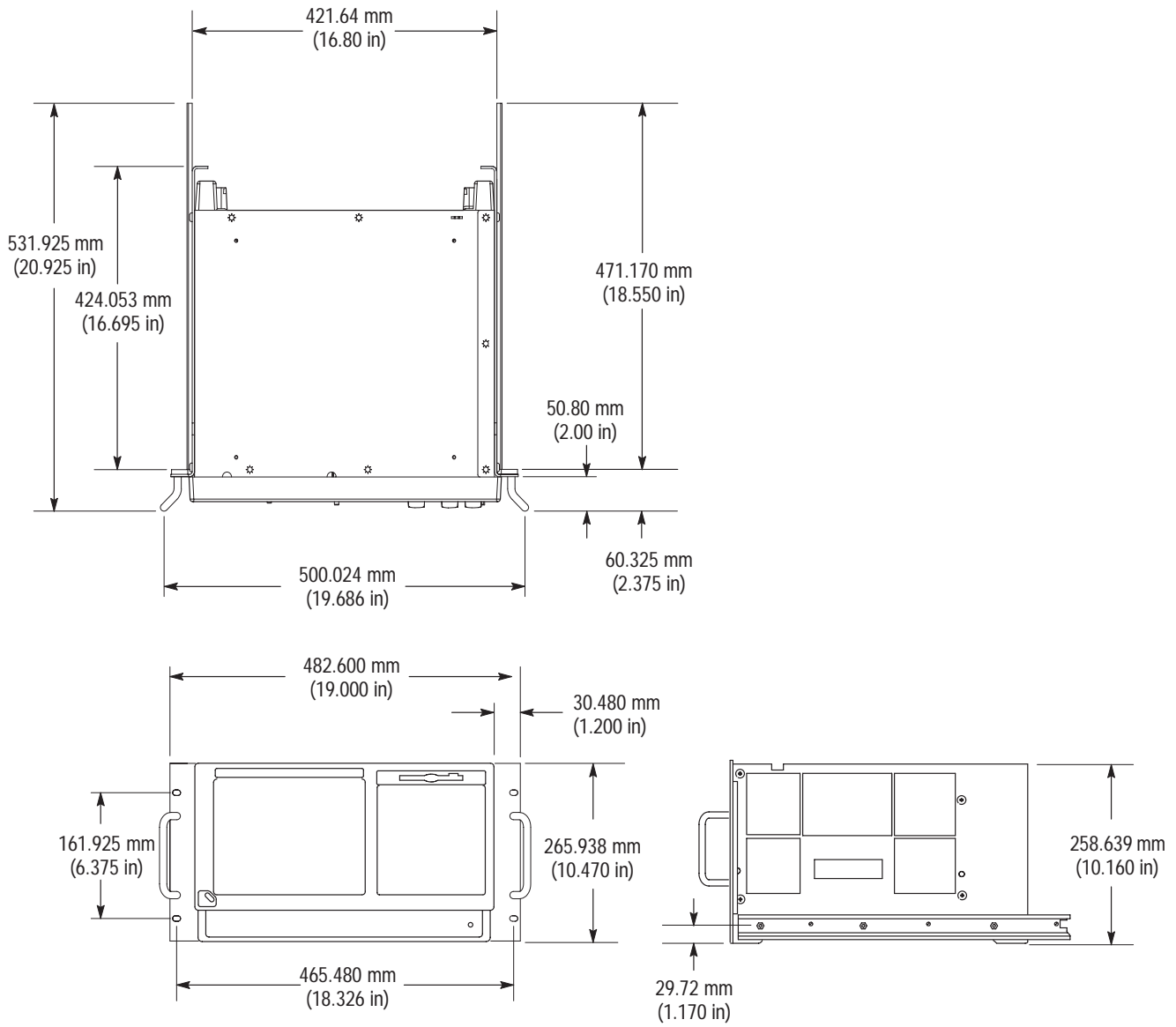

Figure 2: instrument with Rack Adapter Installed

Installation Instructions

This section contains all procedures needed to rackmount the TDS7000 & TLA 600 Series instruments.

Minimum Tool and Equipment List

The following tools are required to attach the rack-adapter kit hardware, install cabling hardware, and mount the rack-adapted instrument into a standard equipment cabinet. All tools are standard tools that are readily available.

Table 2: Tools required for rackmount installation

Item no.	Name	Description
1	Screwdriver handle (magnetic)	Accepts 1/4 inch hex-head driver tips
2	No. 2 Phillips or Pozidrive tip	Phillips or Pozidrive-driver tip for number 2 size screw heads
3	T-15 Torx tip	Torx [®] -driver tip for T-15 size screw heads
4	3/8 inch wrench	Wrench or nutdriver can be used to install slides

These instructions are for personnel who are familiar with servicing the product. If you need further details for disassembling or reassembling the product, refer to the appropriate product manual. Contact your nearest Tektronix Service Center or Tektronix Factory Service for installation assistance.



WARNING. To prevent the rackmounted instrument from tipping forward onto the operator, install the instrument so that the operator will be able to access all of its rear devices without pushing down on the instrument.

Verify that the rack does not become unstable with the instrument fully extended. Do not leave the instrument extended when finished accessing the rear panel.

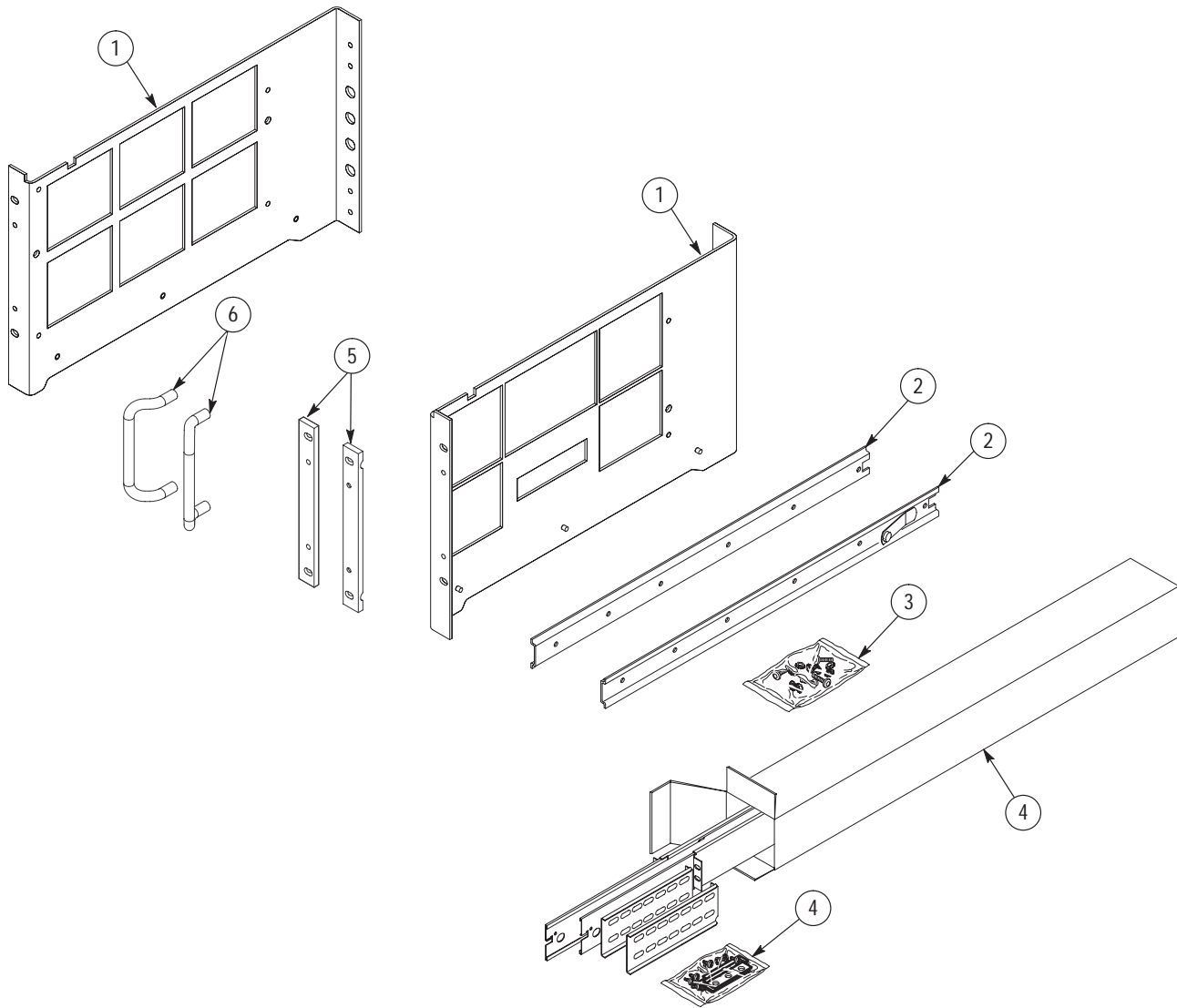

Figure 3: Rackmount kit parts

Remove

Strip the Instrument for Conversion

Equipment Required: Torxdriver with T-15 tip (Items 1 and 3).

NOTE. All parts removed from the instrument in this procedure should be retained for later use. Some of those parts will be reinstalled as you perform this rack conversion. The remainder should be stored in case reconversion to a standard instrument configuration is desired at a later time.

Right-side or left-side references in these instructions assume you are viewing the instrument from the front panel.

1. Remove the Line Cord.
2. Remove the four T-15 Torxdrive screws and snap studs that secure the top cover, and then remove the top cover by lifting the back up while pulling towards the rear.
3. Remove the left-side cover by sliding the cover towards the rear of the instrument.
4. Remove the two T-15 Torxdrive screws that secure the carrying handle to the right-side trim panel. Remove the handle and the trim panel.
5. Remove the five T-15 Torxdrive screws that secure the cabinet bottom to the instrument. Remove the bottom-cover trim from the instrument.

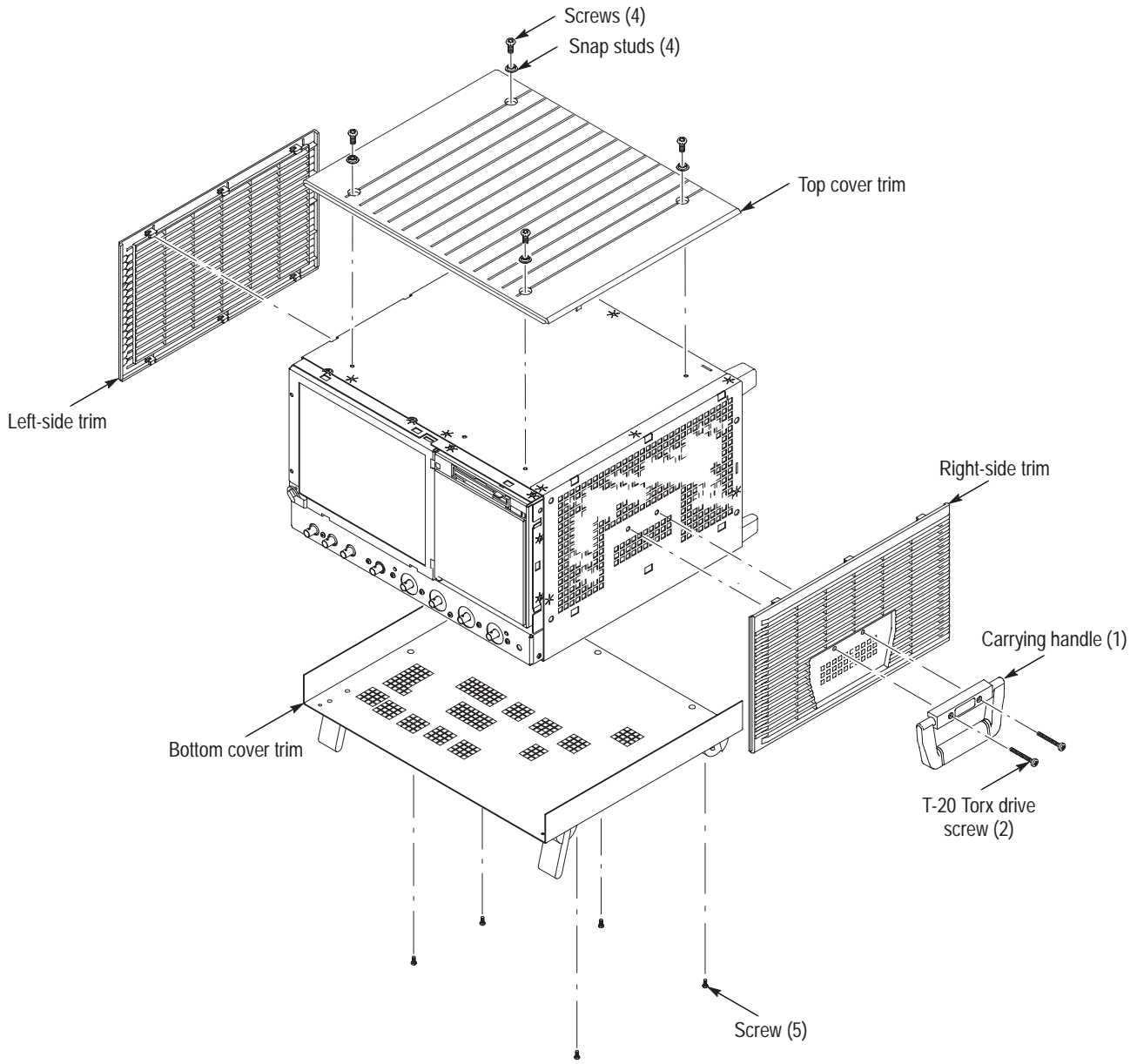

Figure 4: Strip instrument for conversion

Install

NOTE. Preassemble all sub-parts on the right and left-side panels before installing the rackmount panels on the instrument. Refer to Figure 5.

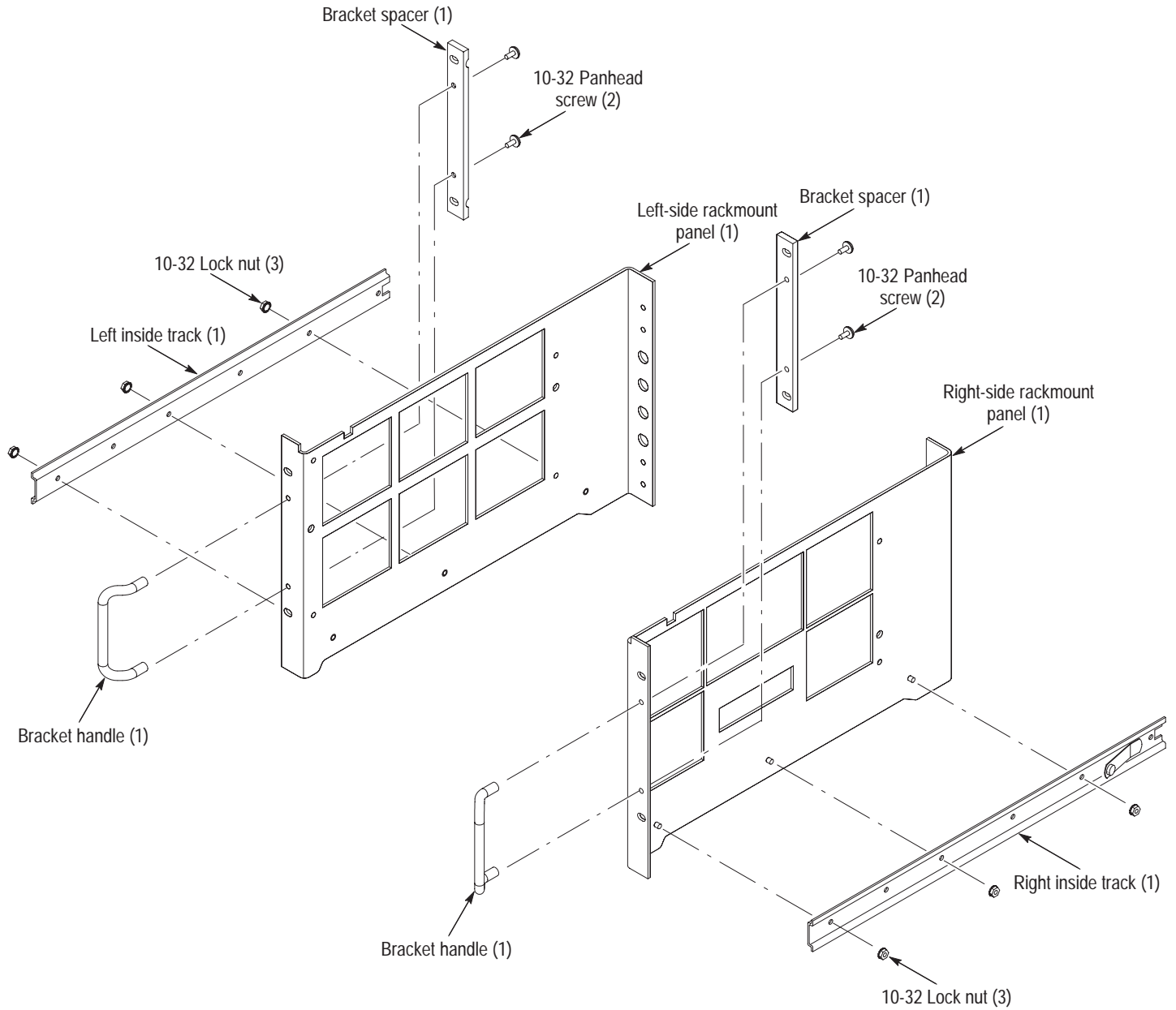

Figure 5: Rackmount panel preassembly

1. Reinstall the top cover by placing the front of the cover onto the instrument first, then lower the back into place. Secure using the four T-15 Torxdrive screws and snap studs.
2. Install the bracket handle and bracket spacer to the right-side rackmount panel. Secure by using the two 10-32 panhead, Phillips screws, applying 15 inch-lbs of torque. Refer to Figure 5, on page 11.
3. Install the right-side rackmount track over the three screw posts on the right-side rackmount panel. Use the six 8-32 locking-nut washer assemblies to secure the right-side rack track onto the rackmount panel, applying 28 inch-lbs of torque.



CAUTION. To prevent the rackmount track from not locking, make sure the track button latch is located towards the bottom of the rackmount panel. Refer to Figure 6.

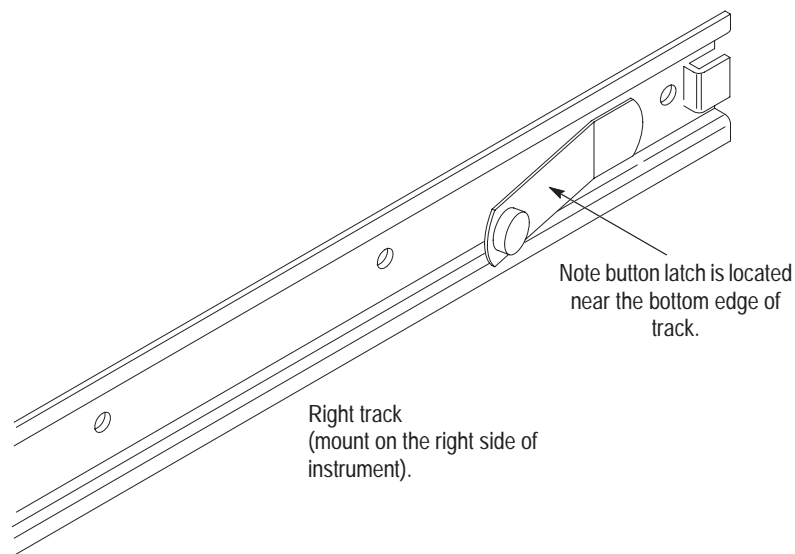

Figure 6: Right inside track identification

4. Install the right-side rackmount panel assembly to the right side of the instrument. Secure it by using the four 10-32 Truss-head phillips screws, applying 28 inch-lbs of torque. Refer to Figure 7, on page 13.
5. Repeat steps 2 through 4 to install the left-side rackmount panel, substituting right-side to left-side.

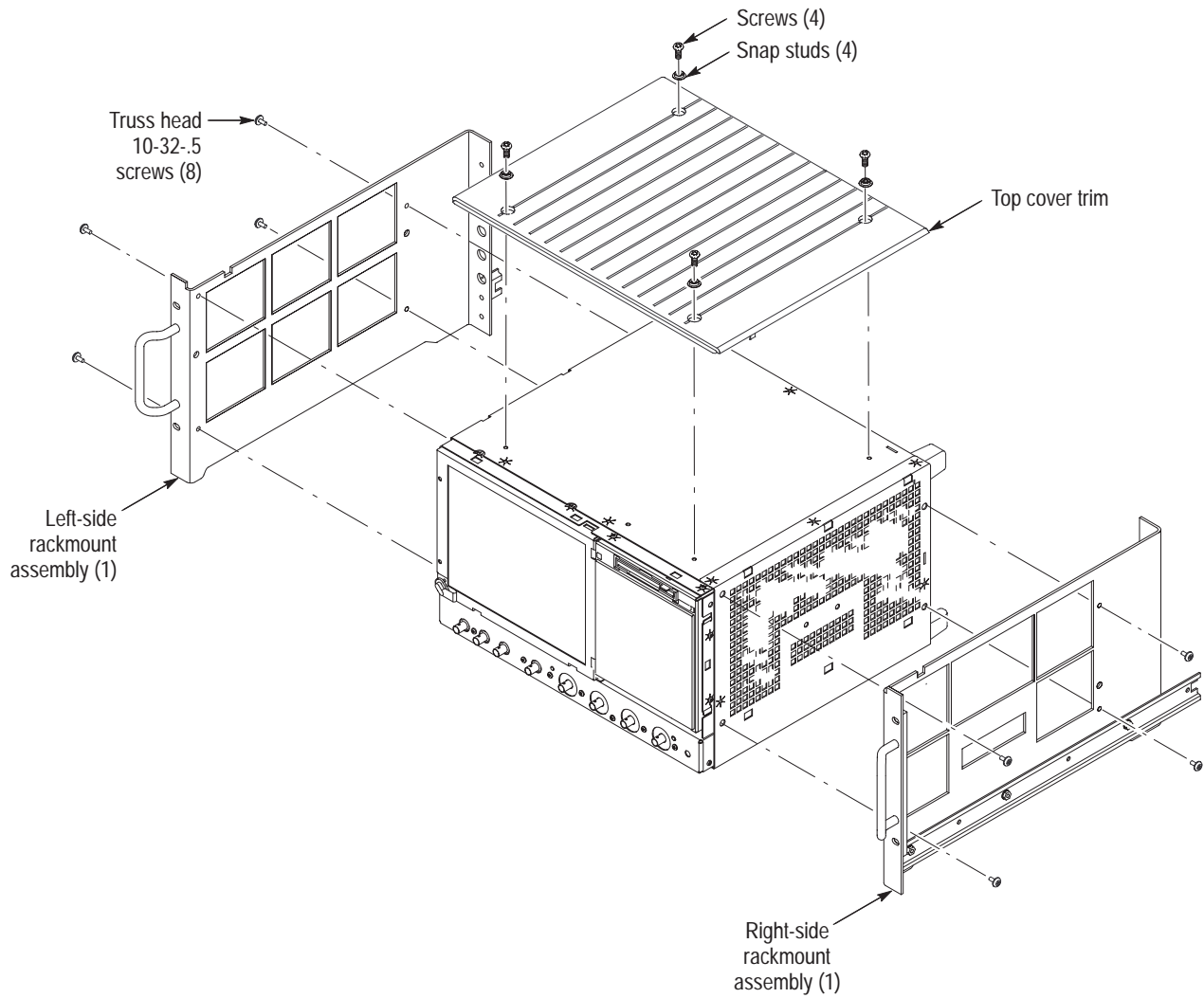

Figure 7: Installation of rackmount assemblies

This completes the installation of the rack-adapter hardware to the instrument. To complete the installation, do the following procedure: *Optional Rear-Panel BNC installation and Rackmount the Rack-Adapted Instrument.*

Rear-Panel BNC Installation (Optional). Does not apply to the OTS9000 Series

Perform this procedure if you wish to route the front-panel inputs to the rear panel.

1. *Orient the oscilloscope:* Set the instrument so its bottom is down with its rear of the instrument facing you.
 - a. *Assemble the hardware:* Unpackage and identify the BNC connector hardware in the cable feed-through kit (Tektronix part number 103-0070-XX) using Figure 8, page 15 as a guide.
 - b. *Mount the BNCs:*
 - Insert a rubber washer over the threaded end of a BNC.
 - Insert the threaded end of a BNC through one of the four holes in the *right* rear bracket so it protrudes out the back of the bracket.
 - Install a $\frac{5}{8}$ inch lock washer over the threads; then install the $\frac{5}{8}$ inch nut. Tighten the nut using a $\frac{5}{8}$ inch wrench.
 - Repeat the subparts just performed to mount the remaining three BNCs.

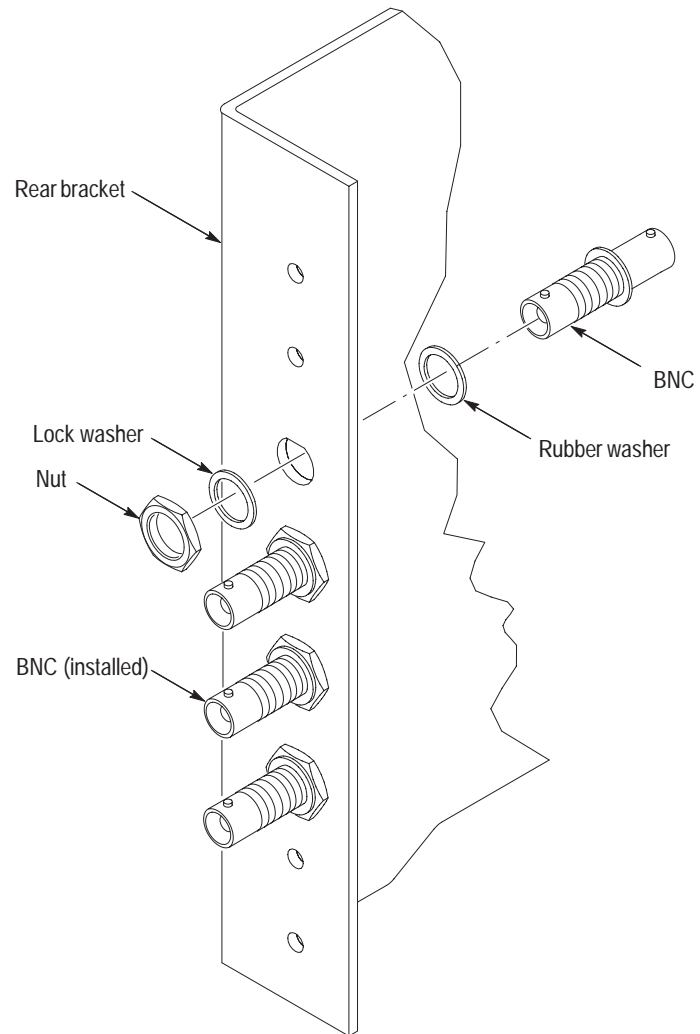

Figure 8: BNC and grommet installation (optional)

Rackmount the Rack-Adapted Instrument

This procedure assembles and installs the slide-out tracks in the equipment rack, and then installs the rack-adapted instrument in the rack.

The slide-out tracks permit the rack-adapted instrument to be extended out of the rack for rear-panel and connector maintenance without removing the instrument from the rack.



WARNING. *If slide-out track assemblies are disassembled for maintenance, do not interchange the left and right inner tracks when reinstalling them in the left and right outer tracks. If you do so, you will defeat the extension stop (safety latch) feature of the tracks. Equipment could, when extended, come out of the slides and fall from the rack, possibly causing personal injury and equipment damage.*



WARNING. *To prevent the rackmounted instrument from tipping forward onto the operator, install the instrument so that the operator will be able to access all of its rear devices without pushing down on the instrument.*

Verify that the rack does not become unstable with the instrument fully extended. Do not leave the instrument extended when finished accessing the rear panel.

NOTE. *The rack hardware kit contains hardware needed for mounting the instrument in several configurations. All of the hardware in the kit will not be needed.*

NOTE. *A standard equipment rack has rails with universal hole spacing. If you use a rack with other than universal hole spacing, you may have to drill additional mounting holes in the rack.*

Install Track Assembly and Instrument into the Rack

Equipment Required: One screwdriver handle (Item1), one number two pozidrive tip (Item 2).

NOTE. *The slide-out track assemblies that are included in this kit (Figure 3-4, page 8) come partially assembled with the inner tracks inside of the outer tracks. Leave them partially assembled to simplify their installation and to avoid accidental swapping of their inner tracks. (See WARNING on the previous page.)*

If assemblies are disassembled, use Figure 9, page 18, to match left and right slides. (Note that when the left and right tracks are oriented as shown, the round cutout is below the square cutout at the end of the both inner tracks.)

Procedure:

1. *Assemble the slide-out track:*
 - a. Identify the right versus left slide-out track assemblies: find the date code label on each assembly. The assembly to be mounted in the left side of the equipment rack (the side nearest the left side of the instrument when it is rackmounted) has a date code that ends with “LH,” for left hand. The right assembly has a date code ending with “RH.”
 - b. Measure the distance between the front and rear rail of the equipment rack.
 - c. Align the rear bracket to the right slide-out track as shown in Figure 9. Note the rear bracket has multiple pairs of mount-through holes. When aligning the bracket and track, be sure to select a pair of holes that mount the rear bracket so the flange-to-flange distance (see figure) matches the front-rail to rear rail. That spacing of the rackmount rack just measured.
 - d. Using a screwdriver with a number two pozidrive tip, secure the rear bracket to the right slide out track using two screws (10-32) and a bar nut as illustrated. Leave the screws loose so that the overall length of the slide-out track assembly can be adjusted when installing it in the rack.
 - e. Repeat substeps c and d to assemble the left slide-out track assembly.
2. *Mount the slide-out track assemblies, using the slide drawer hardware listed in the kit parts list, Figure 3-4:*
 - a. *Select the mounting position in rack:* Select two ½ inch spaced holes in the front rail. Verify that the 4.36 inch and 10.500 inch clearances exist relative to those mounting holes. See Figure 10, page 19.

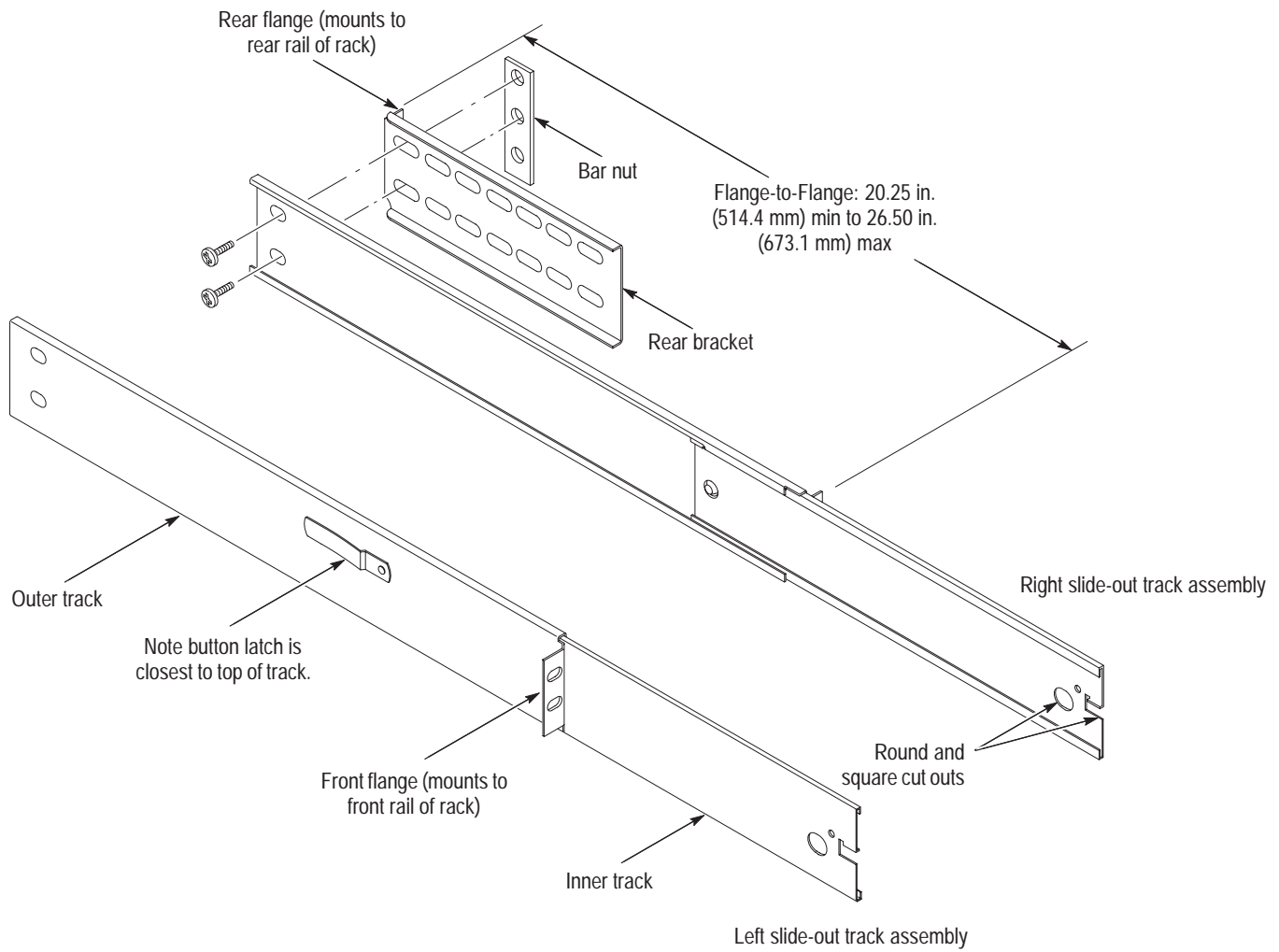

Figure 9: Assembly of slide-out track assemblies

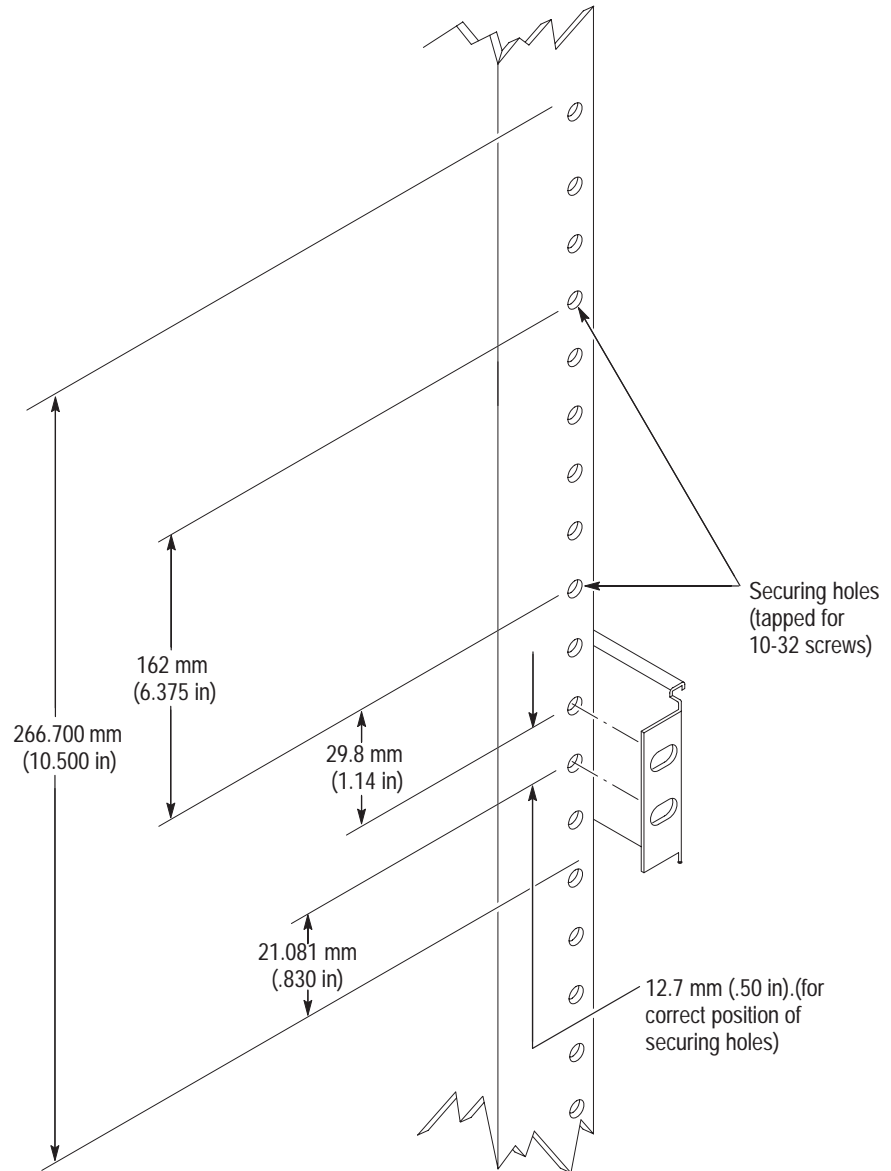

Figure 10: Vertical clearances for rack installation (left-front rail shown)

b. Select mounting method according to rack type:

- To mount the slide-out tracks with their front and rear flanges outside of the front and rear rails, use the method A shown in Figure 11 when doing substep c. Add a bar nut to the installation only if the rails have untapped holes.
- To mount with front and rear flanges inside of rails, use the mounting method B outlined in Figure 11. This mounting method assumes untapped holes.

c. Install in rack: Using the method and hardware determined from substep b, secure the right slide-out track assembly to its front and rear rails. The screws should be fully, but lightly, seated so mounting can be adjusted later.

d. Fix the length of the slide-out track assembly: Tighten the screws, applying 28 inch-lbs of torque, left loose in step 1, substep d to fix the front to rear flange spacing of the slide-out track assembly.

e. Mount the left slide-out track assembly: Repeat substeps a through d to mount the left slide-out track assembly.

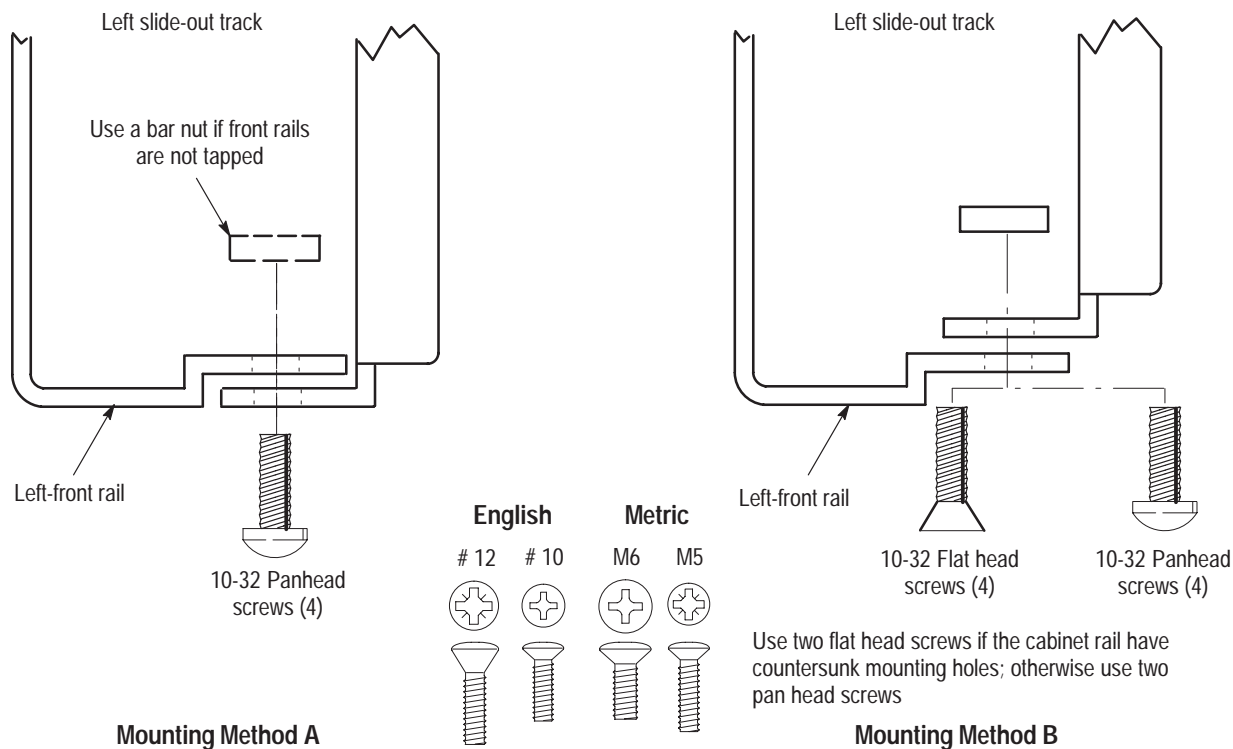

Figure 11: Installation of slide-out track assemblies in rack (top view)

3. Mount instrument in rack:



WARNING. To prevent the instrument from tipping or dropping onto the installers, two or more people should install this instrument into the rack cabinet.

After completing the installation procedure, the installers should verify that the instrument and rack cabinet will not tip forward while the instrument is in the extended position.

a. Install the instrument:

- Working from the front of the rack, slide the inner track of each slide-out track assembly until it extends out the front of the rack. Continue to slide them out until they lock.
- Insert the left and right tracks that extend from the rear of the instrument into the ends of the tracks just extended. Make sure the tracks mounted on the instrument slip inside the inner tracks extended earlier.
- Slide the rear of the instrument backwards until it stops.
- Push to release the button latches, located on the outside of each track, and continue to slide the instrument all the way into the cabinet.

b. Level the rackmounted instrument:

- Tighten the four screws that were left loose at the rear of the rack when you did step 2, substep c, and then pull the instrument part way out of the rack.
- Be sure the four screws that were left loose at the front of the rack are loose enough to allow the slide-out track assemblies to seek their normal positions.
- Retighten the four screws and push the instrument all the way into the rack. If the tracks do not slide smoothly, readjust the level using the method just detailed.
- When leveling is completed, tighten the 10-32 screws using 28 inch-lbs of torque.

c. Secure the instrument and install the line cord:

- Locate and use one of the following types: 10-32 or 12-24 or M5-20 or M6-20 oval head screws. Insert each screw through its nylon finish washer as shown on the data sheet included with the hardware kit.

- Using a number two phillips screwdriver, install the screw/washer assembly in one of the two mounting holes in the right front bracket. Repeat for the second mounting hole. Tighten both screws using 25 inch-lbs of torque.
- Install the two remaining screw/washer assemblies in the left front bracket using the method just described.
- Reinstall the power cord.

■ End of document ■